

## **2006-1126: LOSSLESS IMAGE DECOMPOSITION AND RECONSTRUCTION USING HAAR WAVELETS IN MATLAB FOR ECET STUDENTS**

### **Robert Adams, Western Carolina University**

Robert Adams is an Assistant Professor of Electrical and Computer Engineering Technology in the School of Technology at Western Carolina University. His research interests include mathematical modeling of electrocardiographic applications, 3D modeling, and digital signal processing. Dr. Adams is a senior member of IEEE and a member of ASEE.

### **James Zhang, Western Carolina University**

James Z. Zhang is an Assistant Professor of Electrical Engineering in the Kimmel School of Construction Management, Engineering and Technology at Western Carolina University. Dr. Zhang's research interests include Communications Theory, Wireless Networks, Bandwidth Efficient Modulation Schemes, Signal Design and Information Coding, and Digital Signal Processing Techniques for Communications. Dr. Zhang is a senior member of IEEE and a member of ASEE.

### **Mark Azadpour, Western Carolina University**

Mark Azadpour is an Assistant Professor in the School of Technology at Western Carolina University. His research interests include embedded, storage, and DSP systems as well as VLSI design and verification techniques. Dr. Azadpour is a member of IEEE.

# Lossless Image Decomposition and Reconstruction Using Haar Wavelets in Matlab<sup>®</sup> for ECET Students

## Abstract

A method for introducing the topic of lossless image decomposition and reconstruction to ECET students is presented. The definition and frequency selective properties of the Haar wavelet is introduced. In addition, the application of Haar wavelets to the decomposition and reconstruction of a 1-dimensional signal is explained and serves as a stepping stone to discussing the application to digital images.

## Introduction

In the past few years, the authors reported their efforts of enhancing students' learning by utilizing a systems approach [1] - [4]. These methods focus on the functionality of system blocks to improve students' understanding of system performance parameters. Positive results have been observed in strengthening students knowledge development on certain subjects.

The systems approach has been applied to the development of engineering algorithms. In the Spring semester of 2005, we initiated a project in a Digital Signal Processing class to implement a Matlab<sup>®</sup> algorithm that would produce lossless decomposition and reconstruction of a digital image using wavelets. The reason we chose this topic is twofold. First, the project allows the student to subdivide two complicated processes into manageable system blocks. This training will be helpful when the ECET student graduates and takes on the challenges of the engineering community. Second, the project permits testing and detection of algorithm errors at the output of each system block. This is due to the fact that decomposition and reconstruction are identically reverse processes, which provide the capability for comparison of the output at each stage of decomposition with that of reconstruction. Lastly, the use of images allows the student to visualize the effects of each system block, and thereby gain an understanding of the function of each block. This article reports on some results in introducing this topic into a Digital Signal Processing class. Upon completion, this experimental design is intended to be used in our Microcontroller course for hardware implementation.

## Haar Wavelets

The basic Haar wavelets are a set of low and high pass digital filters that can be used for lossless decomposition and reconstruction [5]. The low pass Haar wavelet is

$$h_0[n] = \begin{cases} 0 & \text{for } 0 \leq n \leq \frac{N}{2} - 3 \\ \frac{\sqrt{2}}{2} & \text{for } n = \frac{N}{2} - 2, \frac{N}{2} - 1 \\ 0 & \text{for } \frac{N}{2} \leq n \leq N - 1. \end{cases} \quad (1)$$

The high pass Haar wavelet is

$$h_1[n] = \begin{cases} 0 & \text{for } 0 \leq n \leq \frac{N}{2} - 3 \\ \frac{\sqrt{2}}{2} & \text{for } n = \frac{N}{2} - 2 \\ -\frac{\sqrt{2}}{2} & \text{for } n = \frac{N}{2} - 1 \\ 0 & \text{for } \frac{N}{2} \leq n \leq N - 1. \end{cases} \quad (2)$$

The low pass nature of  $h_0[n]$  is demonstrated in the digital signal processing class by deriving and plotting the magnitude of the discrete Fourier transform (DFT) of  $h_0[n]$ . The discrete Fourier transform is defined as

$$X[k] = \sum_{n=0}^{N-1} x[n] e^{-j\frac{2\pi nk}{N}} \quad (3)$$

where  $x[n]$  is a finite sequence of length  $N$  defined in the range from  $n = 0$  to  $n = N - 1$ ,  $n$  is the time index,  $X[k]$  is the DFT of  $x[n]$ , and  $k$  is the frequency index of the DFT.  $X[k]$  is a finite complex sequence of length  $N$  defined in the range from  $k = 0$  to  $k = N - 1$ . The magnitude of the DFT of  $h_0[n]$  is derived in the DSP class to be

$$|H_0[k]| = \sqrt{1 + \cos\left(\frac{2\pi k}{N}\right)}. \quad (4)$$

If  $x[n]$  is a sequence generated from an A/D converter, then an original continuous-time signal  $x(t)$  is sampled every  $T_s$  seconds. So  $x[n]$  can be defined as  $x[n] = x(nT_s)$ . In this case,  $X[k]$  is an approximation of the continuous-time Fourier transform of  $x(t)$  and is evaluated at discrete frequencies. The interval between each frequency sample is  $f_\Delta = \frac{f_s}{N}$ , where  $f_s = \frac{1}{T_s}$  is the sampling rate. If  $k$  is substituted for  $k\frac{f_s}{N}$ , then (4) can be expressed as

$$\left| H_0 \left[ k \frac{f_s}{N} \right] \right| = \sqrt{1 + \cos\left(\frac{2\pi k f_s}{N^2}\right)}. \quad (5)$$

Similarly the magnitude of the DFT of  $h_1[n]$  can be shown to be

$$|H_1[k]| = \sqrt{1 - \cos\left(\frac{2\pi k}{N}\right)}. \quad (6)$$

If  $k$  is substituted for  $k\frac{f_s}{N}$ , then (6) can be expressed as

$$\left|H_1\left[k\frac{f_s}{N}\right]\right| = \sqrt{1 - \cos\left(\frac{2\pi k f_s}{N^2}\right)}. \quad (7)$$

Plots of (5) and (7) versus frequency over the Nyquist range are shown in Figure 1. The low pass nature of  $h_0[n]$  is illustrated in Figure 1a and the high pass nature of  $h_1[n]$  is illustrated in Figure 1b. Students are asked to derive and plot (7) versus frequency and are asked to discuss why this is a high pass filter.

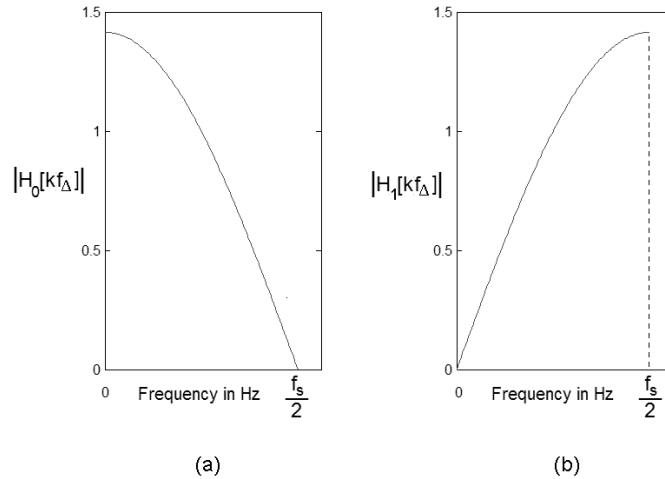

Fig. 1. Magnitude of the DFT of the (a) low pass and (b) high pass Haar wavelets.

### Application to a 1D Signal

The process of decomposing a 1-dimensional signal is first introduced to students in a digital signal processing course. The decomposition process is illustrated in Figure 2. The reconstruction process is illustrated in Figure 3. As an example, consider the digital sequence  $x[n] = \{0, 1, 2, 3, 0, 1, 2, 3\}$ . The two Haar wavelets are  $h_0[n] = \{0, 0, \frac{\sqrt{2}}{2}, \frac{\sqrt{2}}{2}, 0, 0, 0, 0\}$  and  $h_1[n] = \{0, 0, \frac{\sqrt{2}}{2}, -\frac{\sqrt{2}}{2}, 0, 0, 0, 0\}$ . The flipped versions of these sequences are  $h_0[-n] = \{0, 0, 0, 0, \frac{\sqrt{2}}{2}, \frac{\sqrt{2}}{2}, 0, 0\}$  and  $h_1[-n] = \{0, 0, 0, 0, \frac{\sqrt{2}}{2}, -\frac{\sqrt{2}}{2}, 0, 0\}$ . The first step in the decomposition process is to multiply the fast Fourier transform (FFT) of  $h_0[-n]$  by the FFT of  $x[n]$ . The FFT is simply an efficient implementation of the DFT. This product in the frequency domain effectively passes  $x[n]$  through the Haar low pass filter. For this example, the result of this product is  $X_{lp}[k] = \{16.97, 0, 5.657j, 0, 0, 0, -5.657j, 0\}$ . Next we perform the inverse FFT of  $X_{lp}[k]$  to yield  $x_{lp}[n] = \{2.121, 0.707, 2.121, 3.536, 2.121, 0.707, 2.121, 3.536\}$ . Next we

down sample  $x_{lp}[n]$  by a factor of 2 to obtain the low pass sequence  $f_0[n] = \{2.121, 2.121, 2.121, 2.121\}$ . Similarly, we multiply the FFT of  $h_1[-n]$  by the FFT of  $x[n]$  to obtain  $X_{hp}[k] = \{0, 0, 5.657, 0, 5.657, 0, 5.657, 0\}$ . We perform the inverse FFT of  $X_{hp}[k]$  to yield  $x_{hp}[n] = \{2.121, -0.707, -0.707, -0.707, 2.121, -0.707, -0.707, -0.707\}$ . Next we down sample  $x_{hp}[n]$  by a factor of 2 to obtain the high pass sequence  $f_1[n] = \{2.121, -0.707, 2.121, -0.707\}$ .

In the reconstruction process, the two decomposed sequences  $f_0[n]$  and  $f_1[n]$  are up sampled by a factor of 2 to obtain the sequences  $f_{0up}[n] = \{0, 2.121, 0, 2.121, 0, 2.121, 0, 2.121\}$  and  $f_{1up}[n] = \{0, 2.121, 0, -0.707, 0, 2.121, 0, -0.707\}$ . The sequence  $f_{0up}[n]$  is passed through the low pass Haar wavelet by multiplying the FFT of  $f_{0up}[n]$  by the FFT of  $h_0[n]$ . The result is  $F_{0uplp}[k] = \{12, 0, 0, 0, 0, 0, 0, 0\}$ . Similarly, the sequence  $f_{1up}[n]$  is passed through the high pass Haar wavelet by multiplying the FFT of  $f_{1up}[n]$  by the FFT of  $h_1[n]$ . The result is  $F_{1uphp}[k] = \{0, 0, -4 + 4j, 0, -4, 0, -4 - 4j, 0\}$ . The low pass and high pass signals are added to produce  $F_{0uplp}[k] + F_{1uphp}[k] = \{12, 0, -4 + 4j, 0, -4, 0, -4 - 4j, 0\}$ . The inverse FFT of this sequence produces the original sequence  $x[n] = \{0, 1, 2, 3, 0, 1, 2, 3\}$ .

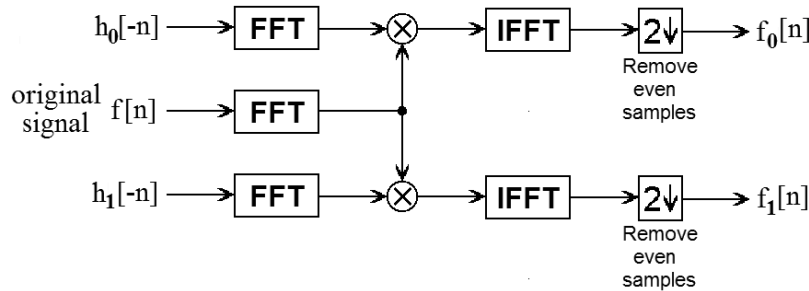

Fig. 2. Decomposition of a 1-dimensional signal.

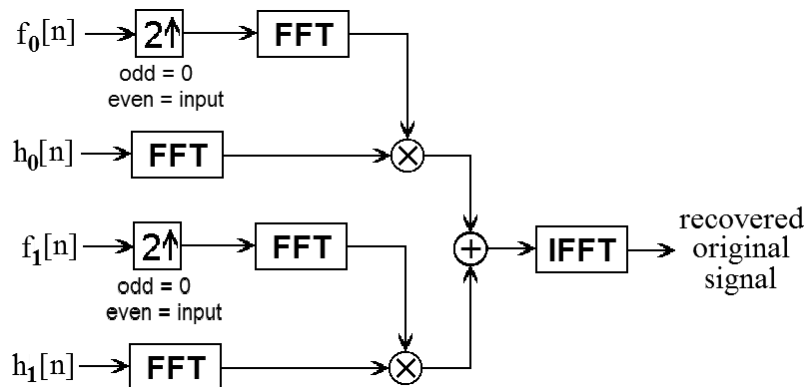

Fig. 3. Reconstruction of a 1-dimensional signal.

## Application to an Image

The processes of image decomposition and reconstruction are illustrated in Figure 4. Each stage of image decomposition and reconstruction incorporates the following elements into the design:

- 1) Generation of Haar wavelets - two 256 element arrays used to generate lossless high and low pass image filters.
- 2) One-dimensional (1-D) fast Fourier transform (FFT) to generate lossless high and low pass from the Haar wavelets.
- 3) 2-D FFT to convert the original image from the spatial domain to the frequency domain.
- 4) 2-D matrix multiplication in the frequency domain to pass the original image through high and low pass filters.
- 5) Inverse 2-D FFT to return the filtered image from the frequency domain to the spatial domain.
- 6) Row and column downsampling of the filtered images to generate four decomposed subimages.
- 7) A reconstruction process consisting of row and column upsampling, 2-D FFT, 2-D matrix multiplication, and inverse 2-D FFT to reconstruct the original image.

The results of our class project are shown in Figure 2. A 256 grayscale image (Figure 5a) is brought through three stages of decomposition (Figures 5b-d) and three stages of reconstruction to reproduce the original image (Figure 5e). An error image, shown in Figure 5f, is produced by subtracting the recovered image from the original image. One will observe that no pixel has an error that exceeds  $10^{-12}$  gray levels.

## Conclusion

We have introduced a method to address the topic of lossless image decomposition and reconstruction to ECET students. Further work is projected to incorporate a hardware implementation of the current design into a microcontroller course. The goal of this project is to extend students' knowledge base by introducing them to an engineering project which incorporates both software and hardware design using knowledge gained from different courses. Successful implementation of this project will help students achieve this goal.

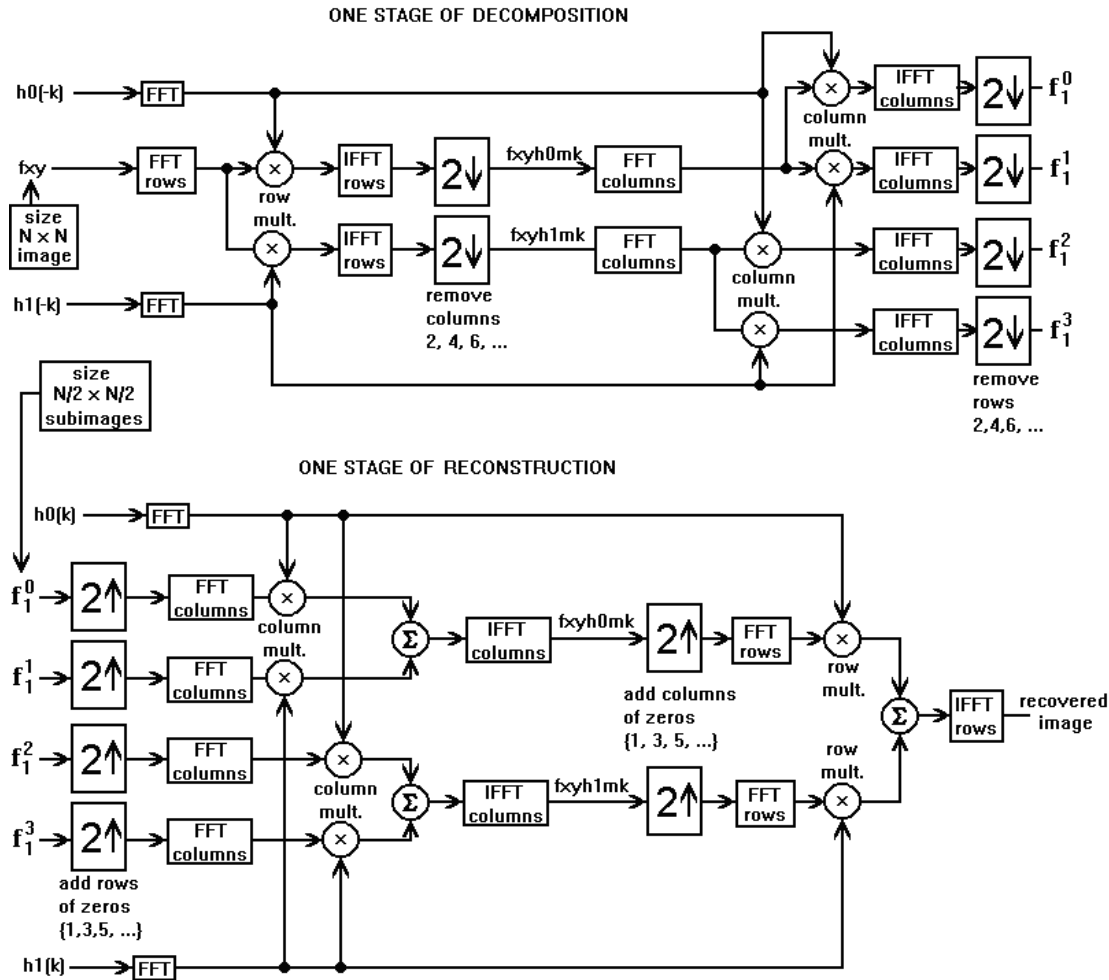

Fig. 4. Block diagram of the algorithm used for lossless image decomposition and reconstruction.

## References

1. Zhang J. Z., Burbank K. and Adams R., A Systems Approach to Teaching "Introduction to Electronic Communications" for ECET Students, *Proceedings of the 2004 American Society for Engineering Education Annual Conference & Exposition, ASEE, June, 2004.*
2. Zhang J. Z., Burbank K., Adams R., A Modular Approach to Teaching "Wireless Communications and Systems" for ECET Students, *Proceedings of the 2005 American Society for Engineering Education Annual Conference & Exposition, ASEE, June, 2005.*
3. Zhang, J. Z., Adams R., Burbank, K., Theory, Practice, and Systems - A New Approach to Teaching Electronic Communications with Matlab<sup>®</sup>. *International Journal of Engineering Education. Vol. 21, No. 3, 2005.*
4. Zhang, J. Z., Adams R., Burbank, K., The Design of RF Labs using Mini-Circuits Modules to Improve the Quality of Teaching in a Course on Wireless Communications and Systems. *World Transactions on Engineering and Technology Education. Vol. 4, No. 1, pp.39-42, 2005.*
5. Daubechies, I., Ten Lectures on Wavelets. *Society for Industrial and Applied Mathematics, 1992.*



(a)

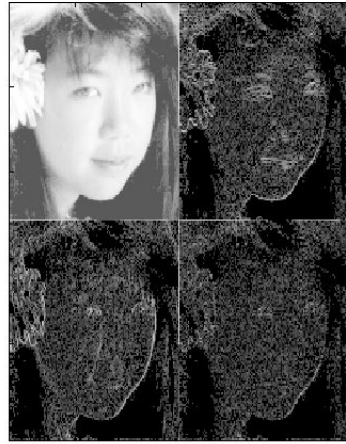

(b)

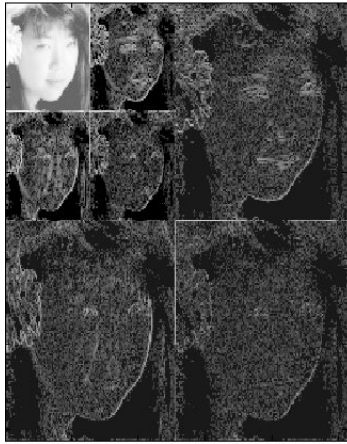

(c)

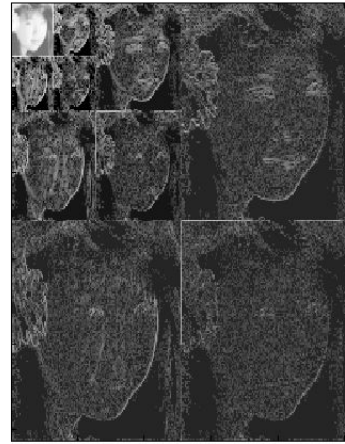

(d)



(e)

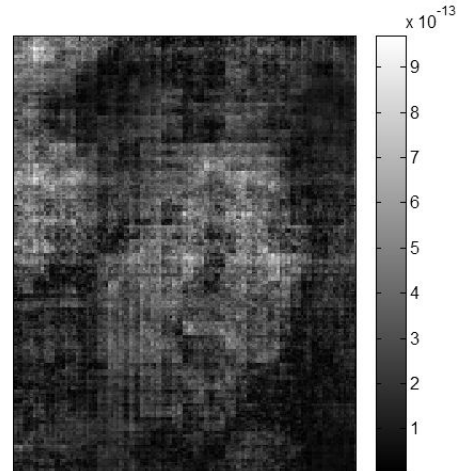

(f)

Fig. 5. Images produced in wavelet decomposition and reconstruction. (a) Original image displayed in 256 gray levels, (b) First stage of decomposition, (c) Second stage of decomposition, (d) Third stage of decomposition, (e) Reconstructed image, (f) Error in reconstructed image in units of number of gray levels.