



Cross-Domain Integration of home automation, entertainment, and e-Health using Wireless Sensor Network

Dr. Xiaojing Yuan, University of Houston (CoT)

Dr. Xiaojing Yuan is Associate Professor in the Computer Engineering Technology program of Engineering Technology Department. She is the founder and director of the ISGRIN research lab and actively incorporating undergraduate research activities as part of final project requirements in several undergraduate junior and senior level courses dealing with sensors, instrumentation, and microprocessor hardware and software. Her research interest includes wireless sensor network, quality-of-service enhanced networking protocols, pattern recognition, and data mining.

Prof. Xiaohui Yuan, University of North Texas

Xiaohui Yuan received B.S. degree in Electrical Engineering from Hefei University of Technology, China in 1996 and Ph.D. degree in Computer Science from Tulane University in 2004. After his graduation, he worked at the National Institutes of Health (NIH) as a postdoctoral research scientist from 2005 to 2006 and joined the University of North Texas (UNT) in 2006. He is currently an Associate Professor in the Department of Computer Science and Engineering. He is a recipient of Ralph E. Powe Junior Faculty Enhancement award in 2008 and the Air Force Summer Faculty Fellowship in 2011 and 2012. He is a member of IEEE and SPIE.

Mr. David Adam Harden

Mr. Yang Lu

Cross-Domain Integration of home automation, entertainment, and e-Health using Wireless Sensor and Actuator Network

Xiaojing Yuan¹, Ardavan Moinzadeh¹, Yang Lu¹, David Harden¹, Xiaohui Yuan²

1. University of Houston 2. University of North Texas

Abstract

Recent advances in wireless sensor and actuator network (WSAN) and other emerging technologies are promoting a paradigm shift in the way that traditional domains like home automation, home based entertainment, or e-Health are understood. However, available technologies present different innate characteristics and are hard to integrate. This paper presents our WSAN-based smart home project, mySmart, to demonstrate the innovative integration mechanism developed that not only integrates research- and commercial- oriented WSN platforms at the application layer, but also provides a unified application development environment for building WSAN based monitoring and control systems. mySmart integrates cross-domain home applications such as home automation, entertainment, and e-Health and addresses one of the major challenges in the home automation system design: minimizing the power consumption without compromising the customers comfort level. It combines hybrid-node networking with Web access in three-layer architecture. The system integrates TinyOS-based mica motes deployed in mesh network and National Instrument (NI) LabVIEW-based WSN nodes using star topology to monitor the home environment and the health status of the nodes themselves. The environment data includes temperature, humidity, light intensity, sound, motion, as well as the physiological signals such as body temperature and heart beats from a person (e-Health). The health status information of mySmart includes networking reliability (i.e., link quality and packet delivery ratio) and the power consumption of the WSN node that is battery powered. All the monitoring data are wirelessly collected and visualized in an application developed in LabVIEW, which makes control decisions based on the data collected and the control strategy defined by the user. The control commands are then disseminated wirelessly to the specific actuators (fans, LED light, speaker, etc.). The mySmart Architecture provides the flexibility for future expansion by separating the sensing, networking, and controlling and visualization. It can be easily adapted to support various courses in the science, engineering, and technology program from freshman to senior level. The demonstration of the project to our junior level instrumentation and measurement class is very successful. Students get to see how what they are learning can be used in real world project that is highly relevant to their own life.

Introduction

Advances in wireless sensor and actuator networks (WSAN) technology and other emerging technologies are enabling a paradigm shift in the way that traditional domains of smart home, such as entertainment, automation and e-Health, are understood. However, there is no systematic mechanism to integrate them together with guaranteed performance and efficiency.

Our smart home project, mySmart, demonstrates the systematic integration mechanism we developed that seamlessly integrates new and emerging technologies together with performance guarantee. mySmart handles the integration from three aspects: the WSAN based monitoring and control; user interface design; and power management. This paper presents the details of all three aspects, starts from its architecture; integration of research- and industry-oriented WSAN platforms [1-3]; its unified and versatile user interface that incorporates voice recognition [4,5]; and its power management [6,7].

mySmart Architecture

As shown in Figure 1, mySmart has three sub-systems that work cooperatively to deliver its functions with satisfactory performance guarantee: WSN that monitor the environment and provide automated feedback control to ensure comfort level at home, unified and versatile user interface that provides intuitive human-machine interface; and energy harvesting and power management.

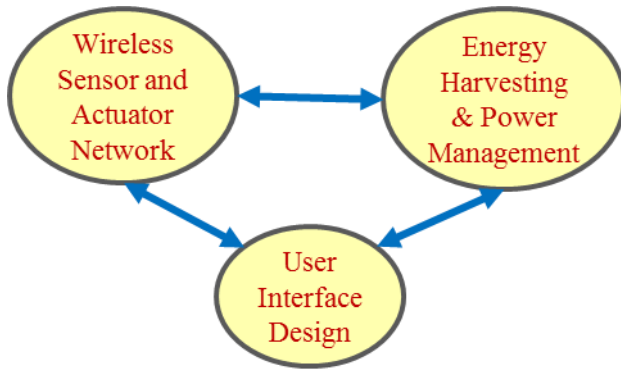

Figure 1 Three Sub-Systems of mySmart

of the WSN. Power management is realized on each node by ensuring low-power listening and at the system level by balancing communication load and identifying the best multi-hop route. The power management functions ensure the sustainability of the whole system, especially the WSN nodes, so that it can have the longest lifetime and function well without human intervention. The unified and versatile user interfaces, including data visualization, analysis, and control functions, have been developed across multiple platforms (such as PC/Laptop, Webpage, and mobile device) to ensure best user experience with the system. Voice recognition has been incorporated to make the mySmart human-machine interaction more intuitive.

Figure 2 shows the architecture of the mySmart testbed and provides an overview on WSN platforms used, voice recognition capability, and application software development environment.

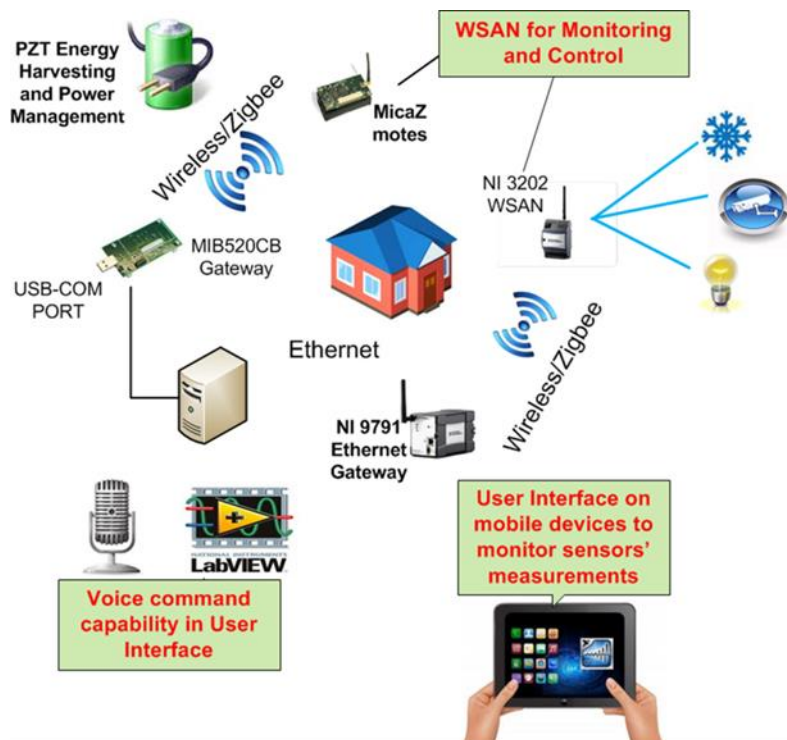

Figure 2 mySmart System Architecture

Wireless Sensor and Actuator Network

Working on an open architecture, the WSAN sub-system employs various sensors and actuators, and provides option to utilize both wired and wirelessly communication. Control logic strives to achieve the balance between maintaining the comfort level of the environment and the energy consumption of the system adaptively and optimally.

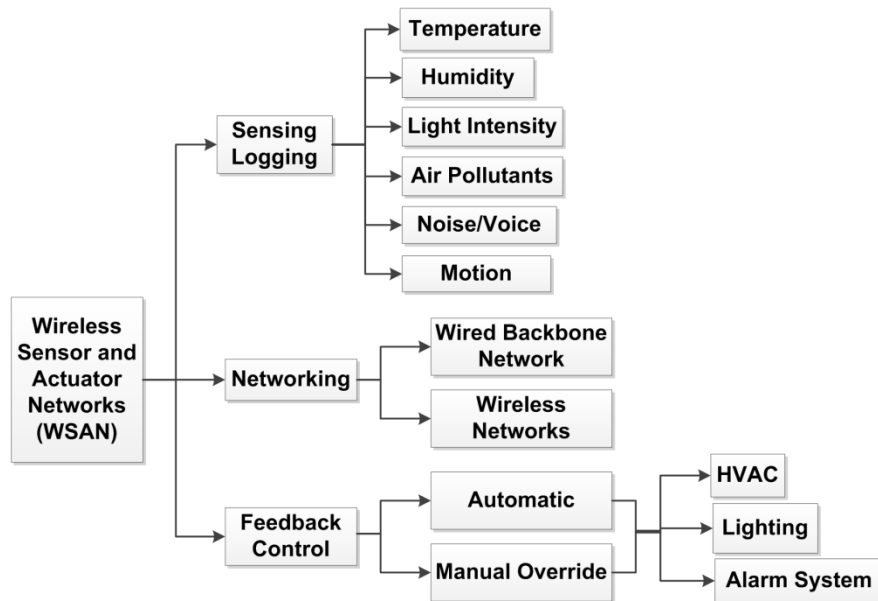

Figure 3 mySmart WSAN Sub-

Figure 3 shows in details the sensors and actuators used in the mySmart test bed; the networking aspects and the decision making functions. mySmart utilizes both WSN based on IEEE 802.15.4, including its extension in Zigbee and the wireline backbone network that enables data sharing via the cloud. It also integrated research-oriented TinyOS-based WSN platform (mica motes) [8-10] and industry-oriented NI

WSN nodes [3, 11-13] by developing an application layer system, mySmart, in LabVIEW that takes measurements from both mica motes and NI WSN nodes and provides real-time feedback control via NI's WSN node (NI WSN-3202 [14]). In addition to the data logging and visualization, simple control logic is integrated into the mySmart test bed that automatically control the HAVC (simulated by a fan in mySmart), lighting system (simulated with LEDs), and security system (simulated by speaker that plays alarmingly loud music and flashing bright LED to deter the theft). Users can always override any settings that trigger automatic feedback control. For example, even though ventilation fan is setup to get started when temperature exceeds 78°F, users can always turn it on via user interface even when the temperature is still way below 78°F.

User Interface Design

We design a uniform and versatile user interface before implementing it across multiple hardware platforms, including PC/laptop, to web pages, to mobile devices, as shown in Figure 4 (a). This practice streamlines the human machine interface of the mySmart to ensure best user experience with the system.

All user interfaces provide data/waveform visualization and simple analysis functions that can be fed into control strategies. In addition,

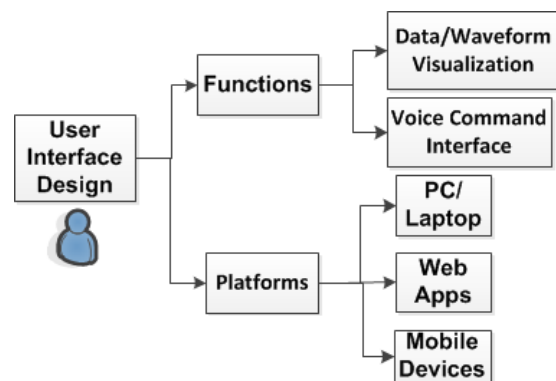

Figure 4 (a) mySmart User Interface

voice recognition capability is also integrated in all user interfaces to provide a more intuitive interaction mechanism. System logic is designed such that human commands (whether in the



Figure 4 (b) Three panels user interface on computer

form of voice or clicking on the control button) always get the highest priority. For example, instead of waiting for the next communication time to read the new monitoring measurement, user can interrupt the system loop and ask for current temperature or humidity values. The system will respond by activating the corresponding sensors and wireless communication radios to deliver the readings within seconds. Figure 4 (b) shows the user interface design and three panels for monitor and control on computer. A similar monitoring user interface was implemented using NI Data Dashboard [11]. User can download the application onto their mobile device and check the home environment condition remotely. Current NI data dashboard does not support feedback control for Android OS [27]. Thus, only the monitoring functions were implemented for the dashboard version of the mySmart.

Energy Harvesting and Power Management

Due to the desire of minimum human intervention after deploying a WSN, various power management mechanisms have been developed to minimize power consumption at each node [6-7, 15,16], and to budget power consumption of the whole network [17-21]. Power management is realized in mySmart from two levels. (1) At the node level, in the interest of extending battery

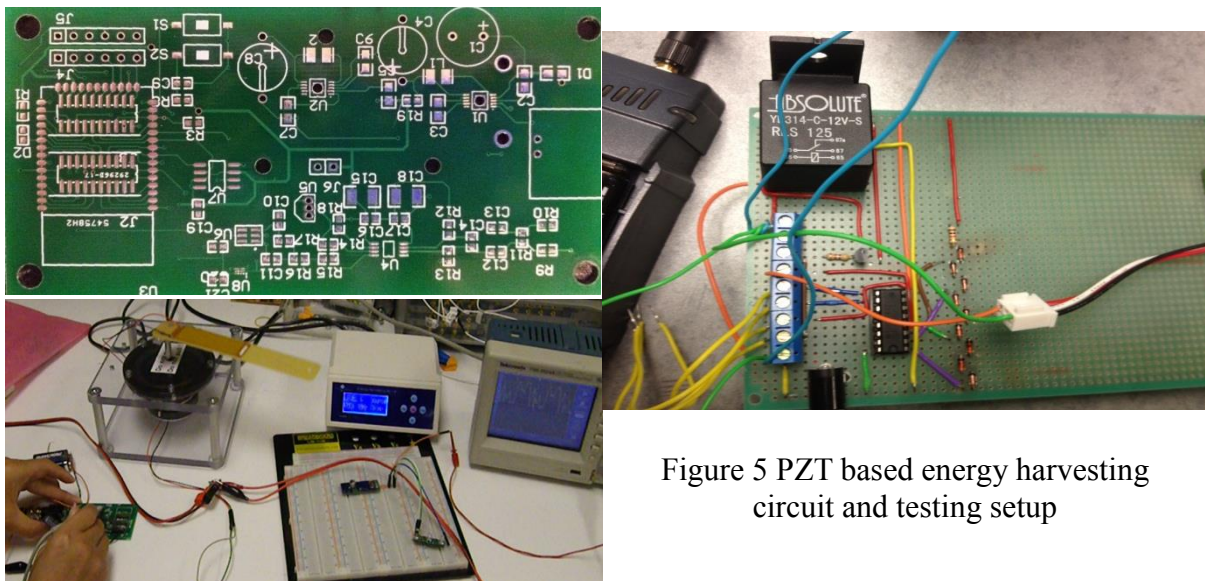

Figure 5 PZT based energy harvesting circuit and testing setup

lifetime, communication radio is duty cycled on and off to prevent any waste of energy. For example, the two popular radios (CC1000 [22] and CC2420 [23]) used in wireless communication consume anywhere from 7.4 to 18.8 mA power when they are turned on and listening. (2) At the system (i.e., network) level, communication load is balanced by forming energy-efficient clusters [20] and identify the best multi-hop route [18].

Novel piezoelectric based energy harvesting circuits were also been developed to enable simultaneous vibration monitoring and energy harvesting [24]. Such mechanism enhances the sustainability of WSN used in mySmart by providing supplement to each node's primary power source. Figure 5 shows the energy harvesting circuits designed and testing setup. Further developed is underway to incorporate the setup with WSN.

Conclusion

We successfully integrated the research-oriented WSN platform and the industry-application oriented WSN platform at the application layer. The paper demonstrated the capability of such integration by presents the design, development, and implementation of a WSN-based smart home application, mySmart, across multiple domains from entertainment, to home automation, to e-Health. Figure 6 shows the current version of mySmart testbed. We are extending the concept to incorporate more sensors and actuators to incorporate power harvesting capability from ambient vibration sources as well as transforming the application to run as a real-time stand-alone system on hardware such as NI cRIO [25] or Crossbow Stargate [26]. In addition, we are working with NI engineers to introduce feedback control capability to its Android dashboard version.



Figure 6 mySmart: smart home monitoring and control

References

- [1] J. Hill, M. Horton, R. Kling, L. Krishnamurthy, The Platforms Enabling Wireless Sensor Networks, Communications of the ACM, Vol. 47, No. 6, 41-46, June 2004.
- [2] Tommaso Melodia, Dario Pompili, Ian Akyildiz, A Communication Architecture for Mobile Wireless Sensor and Actor Networks, IEEE SECON 2006, September 2006.
- [3] National Instruments Wireless Sensor Networks: <http://www.ni.com/wsn/>
- [4] Microsoft Speech API: [http://msdn.microsoft.com/en-us/library/ms723627\(v=vs.85\).aspx](http://msdn.microsoft.com/en-us/library/ms723627(v=vs.85).aspx)
- [5] Microsoft Speech API: http://en.wikipedia.org/wiki/Microsoft_Speech_API
- [6] S.W. Arms, C.P. Townsend, D.L. Churchill, J.H. Galbreath, S.W. Mundell. "Power Management for Energy Harvesting Wireless Sensors," SPIE Int'l Symposium on Smart Structures & Smart Materials, San Diego, CA, March 2005, pp.1-9.
- [7] D. Rakhmatov and S. Vrudhula, Energy Management for Battery-Powered Embedded Systems, ACM Transactions on Embedded Computing systems, 2, August 2003
- [8] Philip Levis, David Gay, TinyOS Programming, Cambridge University Press, 2009.
- [9] Chris Merlin, "A Tutorial for Programming in TinyOS," 2009, accessed on Dec. 20, 2012 via http://www.ece.rochester.edu/projects/wcng/code/Tutorial/TinyOs_Tutorial.pdf .
- [10] TinyOS community: <http://www.tinyos.net/>
- [11] National Instruments Data Dashboard, <http://www.ni.com/white-paper/13757/en>

- [12] National Instruments, Getting Started with LabVIEW, Part Number; 373427H-01, 323427H-01, June 2012.
- [13] William Wong, "LabVIEW: Graphical Programming," Electronic Design, Oct. 2006. Accessed on Dec. 20, 2012 via <http://electronicdesign.com/embedded/labview-graphical-programming>.
- [14] NI WSN-3202 programmable analog input node:
<http://sine.ni.com/nips/cds/view/p/lang/en/nid/207088>
- [15] Y. Xu, S. Bien, Y. Mori, J. Heidemann, and D. Estrin., Topology Control Protocols to Conserve Energy in Wireless Ad Hoc Networks, CENS Technical Report 0006, January 2003
- [16] Wen-Zhan Song, Yu Wang , Xiang-Yang Li, Localized Algorithms for Energy Efficient Topology in Wireless Ad Hoc Networks, MobiHoc, May 2004
- [17] C.J. Rozell and D.H. Johnson, Power Scheduling for Wireless Sensor and Actuator Networks, *IPSN*, April 2007
- [18] M. Haenggi, Energy-balancing Strategies for Wireless Sensor Networks, Proceedings of the 2003 International Symposium on Circuits and Systems (ISCAS '03), May 2003.
- [19] M. Singh and V.K. Prasanna., Energy-Optimal and Energy-Balanced Sorting in a Single-Hop Wireless Sensor Network., IEEE International Conference on Pervasive Computing and Communications (PerCom'03), March 2003.
- [20] M.N. Halgamuge, S.M. Guru, and A. Jennings, Energy Efficient Cluster Formation in Wireless Sensor Networks, 10th International Conference on Telecommunications (ICT'03), March 2003.
- [21] S. Nath and P.B. Gibbons, Communicating via Fireflies: Geographic Routing on Duty-Cycled Sensors, *IPSN*, April 2007.
- [22] TI/Chipcon CC1000 Datasheet. http://www.chipcon.com/files/CC1000_Data_Sheet_2_2.pdf
- [23] TI/Chipcon CC2420 Datasheet. http://www.chipcon.com/files/CC2420_Data_Sheet_1_3.pdf
- [24] Li, Peng, Gu, Haichang, Song, Gangbing, Zheng, Rong, and Mo, Y. L. "Concrete structural health monitoring using piezoceramic-based wireless sensor networks," *Smart Structures and Systems*, v. 6, n 5-6, p731-748, May-June, 2010. (SCI, EI).
- [25] NI CompactRIO: <http://www.ni.com/compactrio/>
- [26] Crossbow Stargate: <http://bullseye.xbow.com:81/Products/productdetails.aspx?sid=229>
- [27] Android company: <http://www.android.com/about/>